

WIND ENERGY – SMALL WIND FOCUS

Event: PCJ Energy Seminar

Presenter: Michelle Chin Lenn – Project Manager, Wigton Windfarm Ltd.

Date: March 3, 2011



WIND INSTALLATIONS IN JAMAICA

1996

0.225 MW



Munro
College

2004

20.7 MW



Wigton I

2010

3 MW



JPS - Munro

18 MW



Wigton II

- Also some houses & businesses
- Usually < 6 kW wind (0.006 MW)

RECENT WIND ENERGY COSTS - LARGE INSTALLATIONS

Regional Examples	Investment	US\$/MW	Wind Turbine Details
Guadeloupe	<ul style="list-style-type: none"> • € 65Million over the last 15 yrs • 26 MW total 	~ 3.5 M	<ul style="list-style-type: none"> ▪ 12 wind farms ▪ 204 wind turbines (60 kW - 275 kW)
Aruba	<ul style="list-style-type: none"> • US\$ 75 M • 30 MW • Commissioned 2009 	2.5 M	<ul style="list-style-type: none"> ▪ 10 x 3 MW
Jamaica - Wigton II	<ul style="list-style-type: none"> • US\$ 49.9 M • 18 MW • Commissioning Dec. 2010 	2.8 M	<ul style="list-style-type: none"> ▪ 9 x 2 MW
JPS – Munro Wind Farm	<ul style="list-style-type: none"> • J\$ 800 M or US\$ 9.3 M • Commissioned Oct. 2010 	3.1 M	<ul style="list-style-type: none"> ▪ 4 x 0.75 MW
Chile - Totoral	<ul style="list-style-type: none"> • US\$ 140 M • Commissioned Dec. 2009 	3.04 M	<ul style="list-style-type: none"> ▪ 23 x 2 MW

WIND ENERGY DEVELOPMENTS

On-shore vs Off-shore Wind Projects: % Cost Breakdown

- Off-shore Civil and Electrical costs higher than onshore

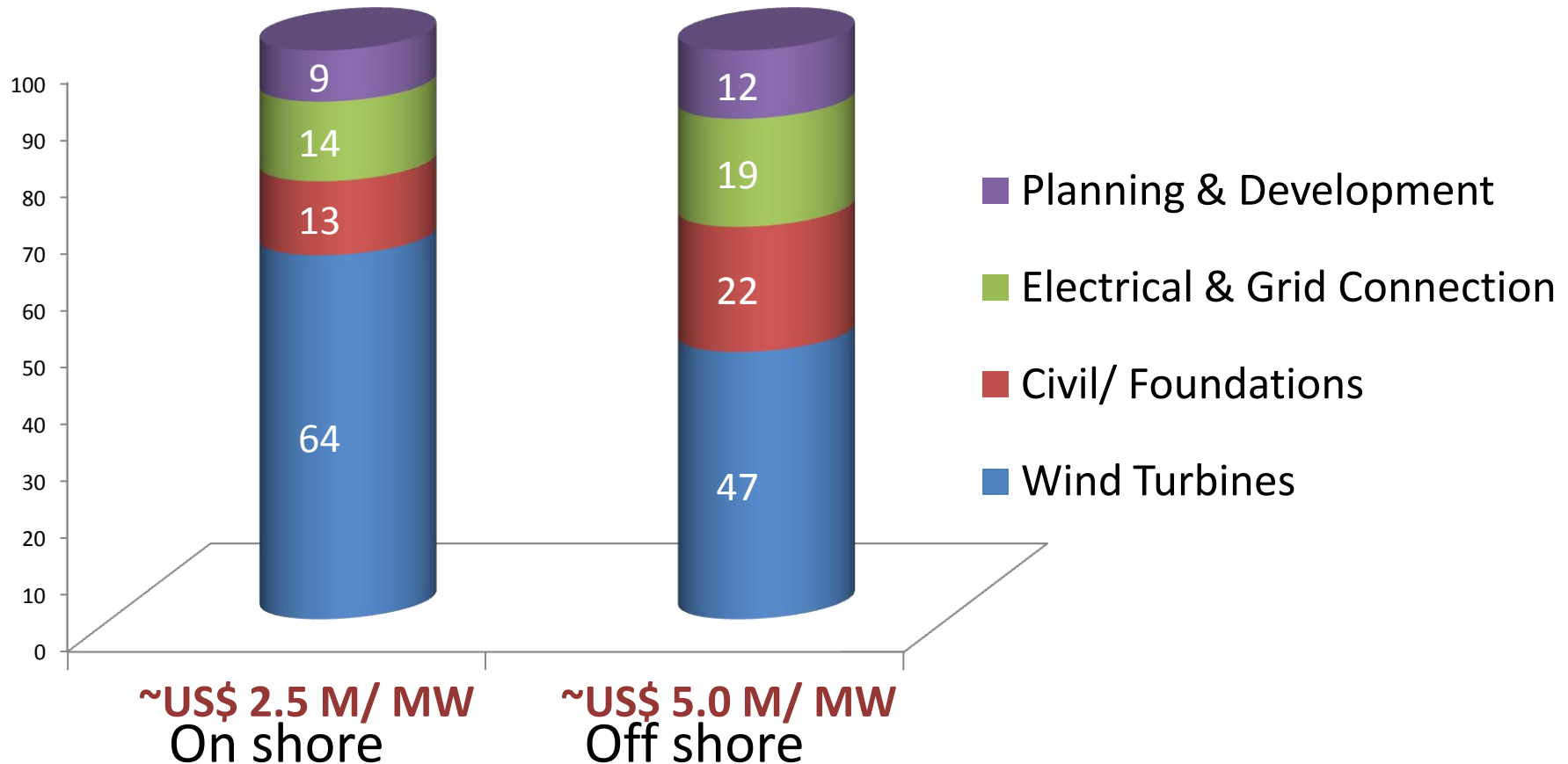

WIND POTENTIAL IN JAMAICA

Mean Annual Avg.

Wind Speeds at 50 m

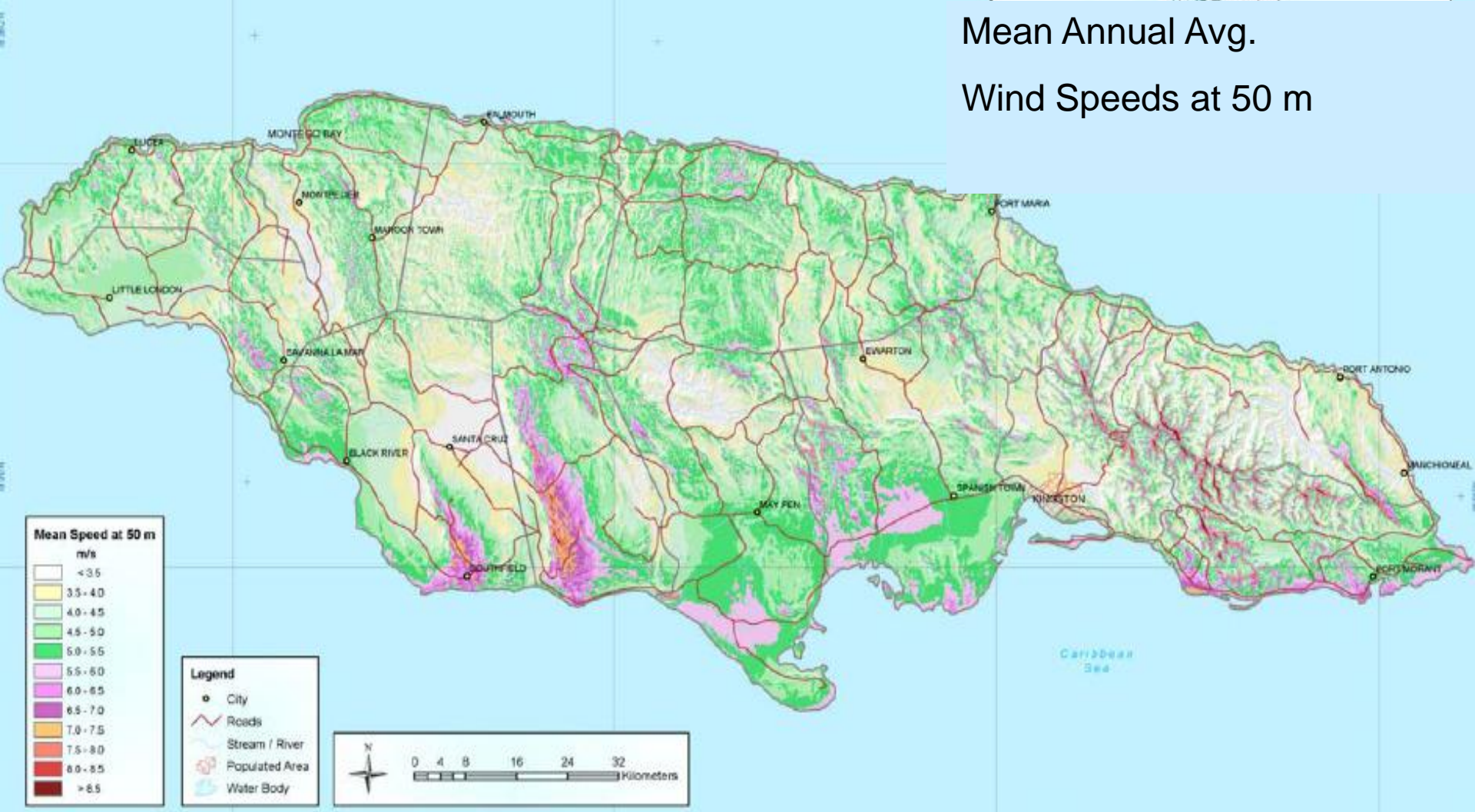

➤ Kingston & St. Andrew - not windy: 3.5 - 4.0 m/s at 50 m

➤ Usually 6-7 m/s required for successful wind projects

WIND CLASSIFICATION

- Larger wind farms require class 4+ winds
- Residential applications class 2+

Classes of Wind Power Density at 10 m and 50 m				
Wind Power Class	10 m		50 m	
	Wind Power Density (W/m ²)	Speed m/s	Wind Power Density (W/m ²)	Speed m/s
1	<100	<4.4	<200	<5.6
2	100 - 150	4.4 - 5.1	200 - 300	5.6 - 6.4
3	150 - 200	5.1 - 5.6	300 - 400	6.4 - 7.0
4	200 - 250	5.6 - 6.0	400 - 500	7.0 - 7.5
5	250 - 300	6.0 - 6.4	500 - 600	7.5 - 8.0
6	300 - 400	6.4 - 7.0	600 - 800	8.0 - 8.8
7	>400	>7.0	>800	>8.8

WIND RESEARCH IN JAMAICA

Studies

- UWI – from 1970's
- PCJ/ RES Studies – 1990's
- JPS/ Unison Studies – 2009+
- Wigton-PCJ/ IDB Programme – 2010 -2013

Aim of IDB Study:

- 1) Investment level data for wind farm projects
- 2) Validate map; **guide to residential wind enthusiasts**



Wind Vane



Anemometer

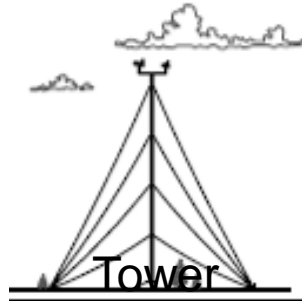

Tower



Data Logger

GLOBAL CUMULATIVE INSTALLED WIND CAPACITY 1996-2009

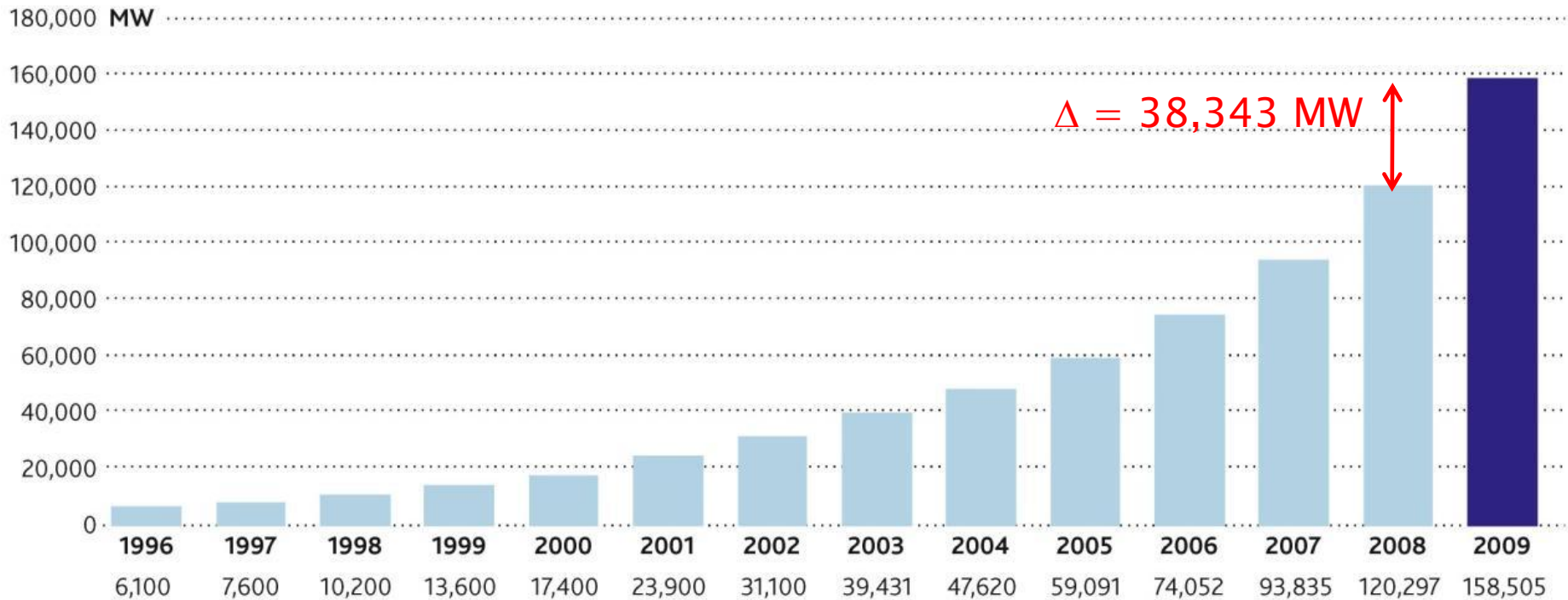

Source: Global Wind Energy Council, 2011

Top 10 New Installations 2009

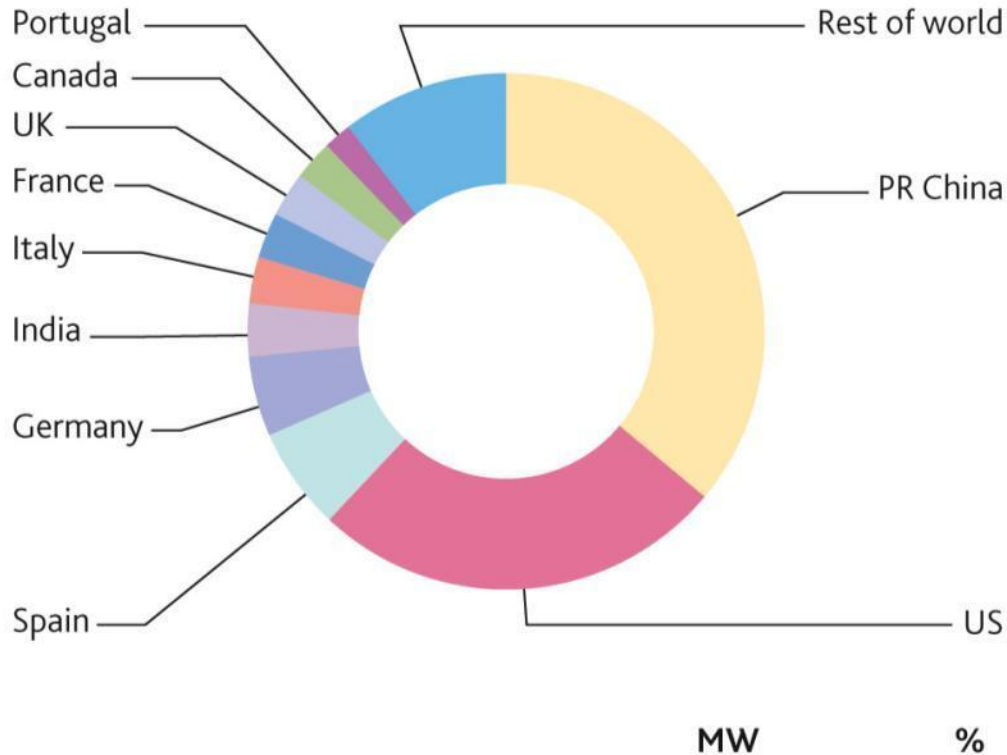

PR China	13,803	36.0
US	9,996	26.1
Spain	2,459	6.4
Germany	1,917	5.0
India	1,271	3.3
Italy	1,114	2.9
France	1,088	2.8
UK	1,077	2.8
Canada	950	2.5
Portugal	673	1.8
Rest of world	3,994	10.4
Total top 10	34,349	89.6
World total	38,343	100.0

Top 10 wind turbine manufacturers by annual market share

1)	Vestas	(<i>Denmark</i>)	12.5%
2)	GE Energy	(<i>USA</i>)	12.4%
3)	Sinovel	(<i>China</i>)	9.2%
4)	Enercon	(<i>Germany</i>)	8.5%
5)	Goldwind	(<i>China</i>)	7.2%
6)	Gamesa	(<i>Spain</i>)	6.7%
7)	Dongfang	(<i>China</i>)	6.5%
8)	Suzlon	(<i>India</i>)	6.4%
9)	Siemens	(<i>Germany/Denmark</i>)	5.9%
10)	RE Power	(<i>Germany</i>)	3.4%

MAJOR LARGE WIND TURBINE MANUFACTURERS

- Acciona Energy (Spain)
- Aeronautica Windpower (USA)
- Alstom Ecotècnia (Spain)
- A Power Energy Systems Ltd. (China)
- AREVA (France) Purchased Multibrid (Germany) in June 2010
- Bornay (Spain)
- Cascade Wind Corp. (USA)
- China Ming Yang Wind Power Group (China)
- Clipper Windpower (USA)
- Daewoo Shipbuilding & Marine Engineering (Korea)
- DeWind (Germany/USA) - bought by Daewoo Shipbuilding & Marine Engineering in 2009
- Doosan (Korea)
- Emergya Wind Technologies (Netherlands)
- Endurance Wind Power (Canada)
- Enercon (Germany)
- Enron Wind (now defunct)
- Gaia-Wind (UK)
- Gamesa Eolica (Spain)
- General Electric (USA)
- Goldwind (China)
- Hanjin (Korea)
- Hi-VAWT (Taiwan)
- Home Energy International (The Netherlands)
- Hurricane Wind Power Makers of the CAT 5 (USA)
- Hyosung (Korea)
- Hyundai Heavy Industries (Korea)
- IMPSA (Argentina)
- INVAP (Argentina)
- Mitsubishi Heavy Industries (Japan)
- NEG Micon, now part of Vestas
- Nordex (Germany)
- Northern Power Systems (USA)
- Norwin A/S (Denmark)
- PacWind (USA)
- Raum Energy Inc. (Canada)
- REpower (Germany) - bought by Suzlon in 2007
- Samsung Heavy Industries (Korea)
- Scanwind (Norway) - bought by General Electric in 2009
- Siemens Wind Power (Denmark/ Germany)
- Sinovel (China)
- Southwest Windpower (USA)
- SoyutWind (Turkey)
- STX Corporation (Korea)
- Suzlon (India)
- Vestas (Denmark)
- Vensys (Denmark / Germany)
- Windiva (India)
- WinWinD (Finland)
- Windflow (New Zealand)

EXAMPLES OF SMALL WIND TECHNOLOGIES

Vertical Axis Wind Turbines (VAWT)



- Platek Services – Canada
- Cleanfield Energy – Canada
- Quietrevolution – UK
- Alternative En. Sys. – Germany
- WePower – USA
- Aerotecture Intl. – USA
- Turby – Netherlands
- Gual Industrie – France
- Shield Innovations – Finland
- Ropatec – Italy
- Helix Wind - USA

Horizontal Axis Wind Turbines (HAWT)



- Bergey Windpower – USA
- Southwest Windpower – USA
- Cascade Wind Corp. – USA
- Wind Simplicity Inc. – Canada
- Ampair – UK
- Proven Energy – UK
- Exmork – China
- Bornay – Spain
- Gaia Wind – Denmark

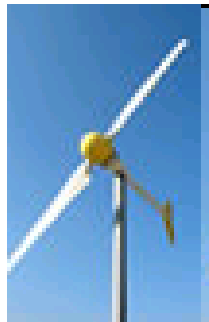

VAWT vs HAWT



VAWT

Advantages

- Generator and gearbox can be housed on the ground, and even some distance away from that turbine
- Requires no yaw mechanism

Disadvantages

- Usually operate near the ground where there's not much wind
- Produce sinusoidal power pulses to drive mechanism
- Repair of the main bearing usually means having to take the whole machine apart
- VAWT is typically about **40% less efficient** than the HAWT in energy production



HAWT

Advantages

- Increased efficiency in power production
- Smooth transfer of power from the rotor to the gearbox
- Generally mounted on taller towers; exposure to higher wind velocities and present smaller footprints on the ground.

Disadvantages

- Can require tall cranes for set-up
- Require a yaw system
- Maintenance required has to be done at the top of a tower

Example of a gearless VAWT

Honeywell (BTPS) - USA

- **Blade Tip Power System (BTPS)** replaces the traditional gear box, shaft and generator of current wind turbine technology
- Creates a “free wheeling” turbine, generating energy from the blade tips (where the speed lies) rather than through a mechanical centre gear
- Rated Power = 2.2 kW
- Cut in wind speed = 0.8 m/s
- Rotor diameter = 1.8 m
- 2500 kWh/yr in class 4 winds (i.e. 5.6 -6 .0 m/s at 10 m)

Source: www.windtronics.com



WHAT IS INVOLVED IN SETTING UP SMALL WIND TURBINES ?

- **Energy Audit** to determine load profile
- **Wind Resource Assessment**
 - Long-term average wind speed for the area at the height that the wind turbine will be mounted to access the free flow of wind
- **Feasibility Study for investment**
- **System Design and Configuration**
- **Permitting** eg. CAA, KSAC etc
- **Procurement and Installation**
- **Maintenance and Monitoring**



- Note CAA advises that if within 2 mile radius of an aerodrome, must request CAA permission

SMALL WIND CONSIDERATIONS

- In cities the air is turbulent because of trees and the variation in heights of buildings.
- Turbulence can wear out a turbine and reduce its life expectancy.
- For performance and reliability, ROT is that the entire rotor of the wind turbine must be situated at least 10 feet above the surrounding trees and buildings.

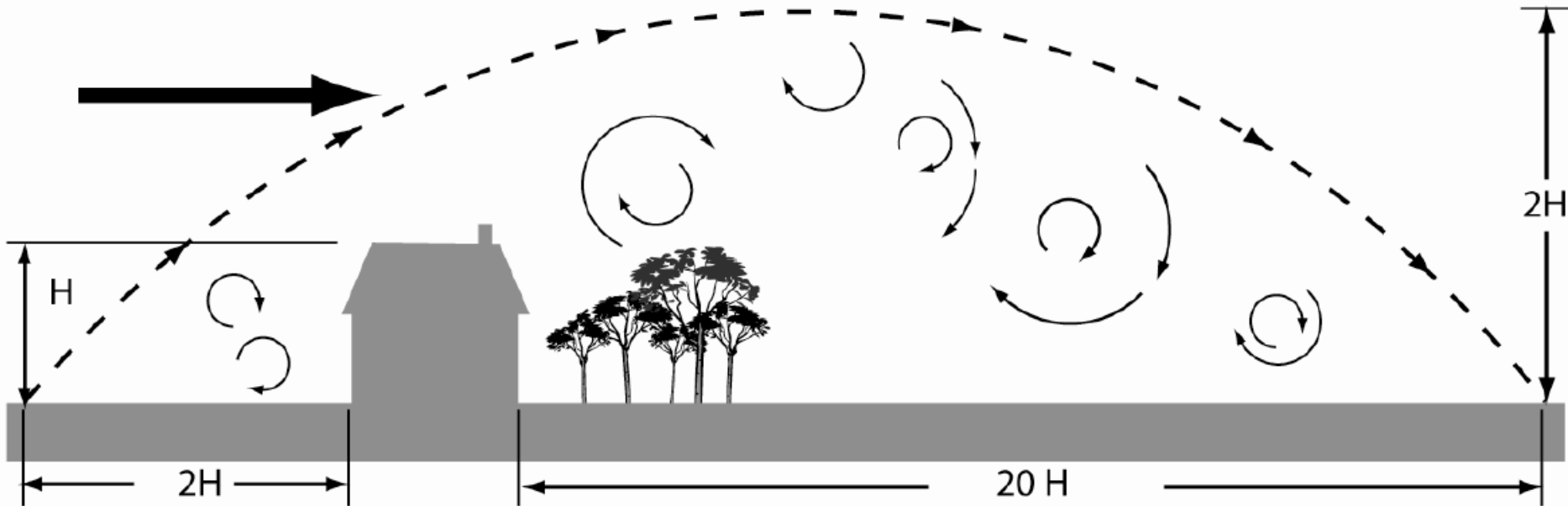

SYSTEM CONFIGURATIONS

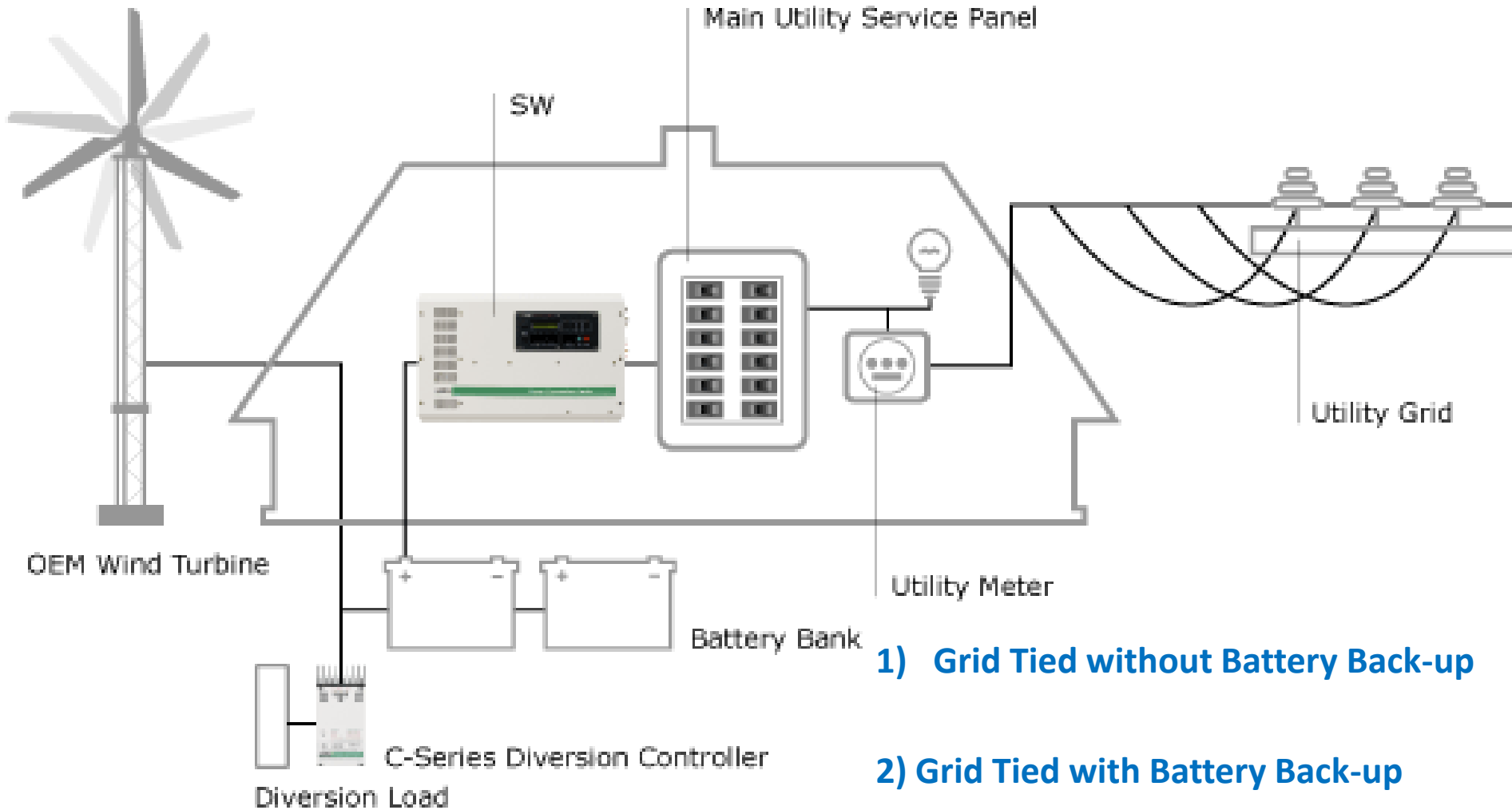

1) Grid Tied without Battery Back-up

2) Grid Tied with Battery Back-up

3) Stand Alone



Cost Example: Bergey 1 kW

Wind turbine	1 kW	= US\$ 2,800
Tower	18m	= US\$ 1,700
Grid tied inverter	1.1 kW	= US\$ 1,900
Labour, wiring, miscl.		= US\$ 200
Total		= US\$ 6,600*

* Batteries, charge controller additional if system has back-up capability

Annual Average Wind Speed (m/s)		3.5	4	4.5	5	5.5	6	6.5
Annual Average Wind Speed (mph)		7.8	8.9	10.1	11.2	12.3	13.4	14.5
Production in kWh (24 VDC)	Daily	1.9	2.8	3.9	5.1	6.4	7.7	8.9
	Monthly	55	85	115	155	195	235	270
	Annually	680	1,010	1,410	1,850	2,320	2,790	3,260

Basis: 4 m/s

Basis: 5 m/s

Incentives

Savings/ month

$$= 85 \text{ kWh} \times \text{US\$ } 0.30/\text{kWh}$$

$$= \text{US\$ } 25.5 \text{ or } \text{J\$ } 2,193$$

Savings/ month

$$= 155 \text{ kWh} \times \text{US\$ } 0.30/\text{kWh}$$

$$= \text{US\$ } 46.5 \text{ or } \text{J\$ } 3,999$$

Due to the long payback periods government may need to introduce some incentives such as rebates or reductions in mortgage rates if renewable energy is incorporated.

Simple Payback Period

$$= \text{US\$ } 6,600 / (25.5 \times 12)$$

$$= \text{21 years}$$

Simple Payback Period

$$= \text{US\$ } 6,600 / (46.5 \times 12)$$

$$= \text{12 years}$$



EXAMPLES OF LOCAL SMALL WIND RETAILERS

- Alternative Power Sources Limited – Kingston & Spanish Town
- Prime Solutions Limited – Kingston
- Sun Source Technologies – St. Ann’s Bay
- A To B Industries – Kingston
- Alternex Energy Systems – Kingston
- Caribbean Solar Energy Co. Limited – Kingston
- Energy Solutions Jamaica – Kingston

Source:

<http://energy.sourceguides.com/businesses/byGeo/byC/Jamaica/Jamaica.shtml>



RENEWABLE ENERGY RATES

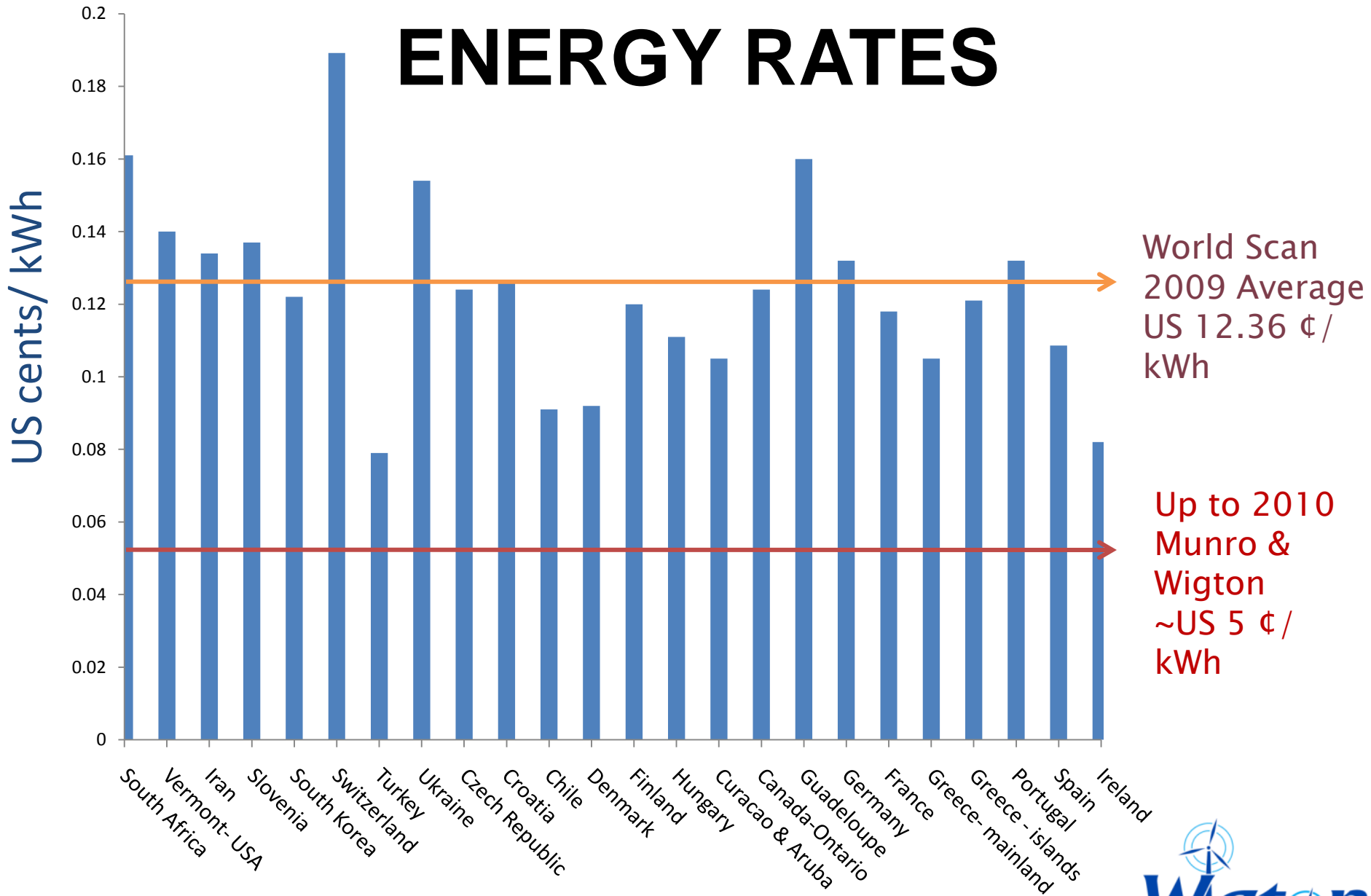

JAMAICA WIND FARM PRICING

Wind Farm	Wind Energy Price (US cents/ kWh)	Comments
Wigton I	10.21	O.U.R. 2010 Rate Determination
Wigton II	10.73	Proposed; Based on Energy Policy
JPS Wind	13.60	Front end loaded to rate to end at 5.639 cents at year 20
Avg. Price	11.51	

WIND FARM BENEFITS FOR JAMAICA

WIND FARM	CAPACITY (MW)	PROJECTED OUTPUT (GWh/ yr)	BARRELS OF OIL AVOIDED (Bbl/ yr)	BARRELS OF OIL – FOREIGN EXCHANGE SAVINGS (@US \$90/ bbl) (US\$)	GHG EMISSIONS AVOIDED (tonnes CO ₂)	POTENTIAL CARBON CREDITS REVENUE(@ min. 5.5€/ CER) (US
Wigton I	20.7	54.4	32,000	2,879,979	45,369	317,902
Wigton II	18.0	47.3	27,826	2,504,329	39,452	276,437
JPS Wind	3.0	7.9	4,638	417,388	6,575	46,073
Annual Benefit	41.7	109.6	64,463	5,801,696	91,396	640,412

RESIDENTIAL ELECTRICITY PRICES

Avg. Prices paid by residential customers	2008	2007	2006	2005	Period Avg.
US cents/ kWh	33.3	27.7	25.8	23.7	27.6

Source: JPS Annual Report

<u>Generation</u>	<u>Electricity</u>	<u>Average Cost</u>
Wind	1.3%	11.3 ¢/ kWh
Non-Wind	98.7%	22.68 ¢/ kWh
Weighted Average for Generation =		22.53

<u>Other System Costs</u>	<u>¢/ kWh</u>
Transmission	0.95
Distribution	3.1
Customer service & admin	1.05
Total	5.1

Source: O.U.R. - Platt's conference 2011

IMPACT OF WIND ON ENERGY PRICES

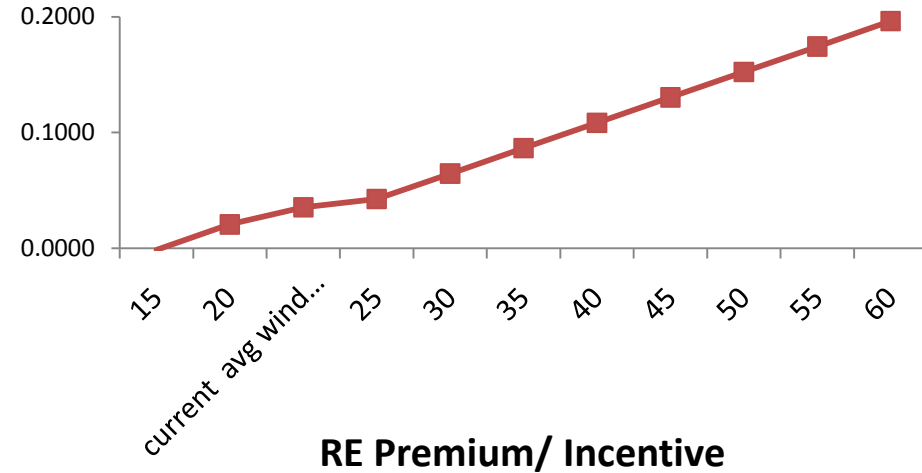
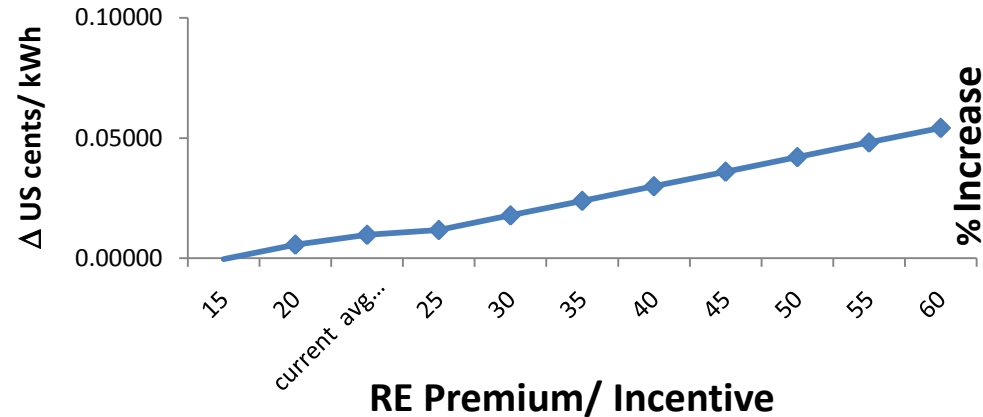

Summary

- Increasing the wind energy incentive from 15% to 60% has **negligible impact on customers bill**
 - Difference of **0.054 c/ kWh** or **0.196 %**
- Based on the larger share of the bill due to fuel generated electricity, the bill will more significantly increase as fuel prices rise